

# REO Sentinel™ – Installation Manual

## Recommended Tools



- Step Ladder (3-4 foot)



- Awl



- #1 Mini Phillips Head Screwdriver



- #6 Regular Phillips Head Screwdriver ( for #6/#8 screws)



- Pencil or other marker



- Drill (drill bits and #6 Regular Phillips Head long shank drivers)



- Digital Camera or Cell phone with Camera

# DO'S AND DON'TS OF INSTALLATION



## Do

## Don't

1. Call customer service if you have any questions: 877-815-7760.
2. Carefully plan the placement of the Sentinel (where the most foot traffic is likely to take place in a property) by taking a photo with your cell phone or digital camera. If you do not like the "view" from your cell phone or digital camera, select an alternate place to install the Sentinel.
3. Move to the farthest corner of the room being selected (living room, kitchen, bedroom) offering the widest angle of view for the camera.
4. Make sure direct sunlight ***will not*** be facing the camera of the Sentinel.
5. Place a door/window sensor on the door/window most likely to be used to gain authorized and unauthorized access to the property.
6. Ensure the arrows  located on the magnets of the door/window sensors, are in the correct position (facing each other – as shown above).
7. Remember to share data with customer service regarding the property, i.e., does the property have the utilities turned on/off, is there a "For Sale" sign, are there any issues that should be resolved prior to a Sentinel unit being installed, etc.
8. Take pictures of the property's outside, poor inside conditions, installed Sentinel Unit and send to [info@reosentinel.com](mailto:info@reosentinel.com).

1. Leave the property before calling customer service at 877-815-7760 to ensure all Sensors have registered to the REO Sentinel and photos received from the unit are clear.
2. Rush through the installation process prior to reading the installation instructions first.
3. Leave behind any trash from the installation process.
4. Forget to dispose or destroy documentation that contains the code for accessing the property.
5. Forget to leave the key in the lockbox and be sure to change the "spin code".
6. Forget when shipping a system back to REO Sentinel, all batteries are to be removed from sensors and the Sentinel unit.
7. Don't hesitate to share with customer service, tips that could help other installers. Your suggestions are welcomed!
8. Don't mount directly facing a door/window or other area where direct sunlight will effect images the Sentinel captures.



# REO Sentinel™ and Remote Sensor Installation Guide

## Section 1 –Installing the Window/Door Sensor (Figure 1)

1. Flip open the battery compartment cover and attach the sensor to the window or door as shown in Figure 1 with supplied screws or industry grade double-sided adhesive tape. (Fit the window or door sensor as high as possible near the top).
2. Be sure the surfaces of the contact magnets are level to each other and no more than  $\frac{3}{4}$ " apart ***with arrows facing each other*** as shown to the right.
3. Install two AA Alkaline batteries remembering to observe polarity.
4. Place a numbered sticker on the inside of the battery compartment to assure proper recording of sensor locations.
5. Be sure the DELAY switch is set to MIN to instantly trigger an alarm when the window or door is opened.
6. Press and hold the TEST button on the device for 3-5 seconds. When released the red light should blink.
7. Leave the battery compartment door open for now and move on to the next Window/Door sensor and complete these same steps.

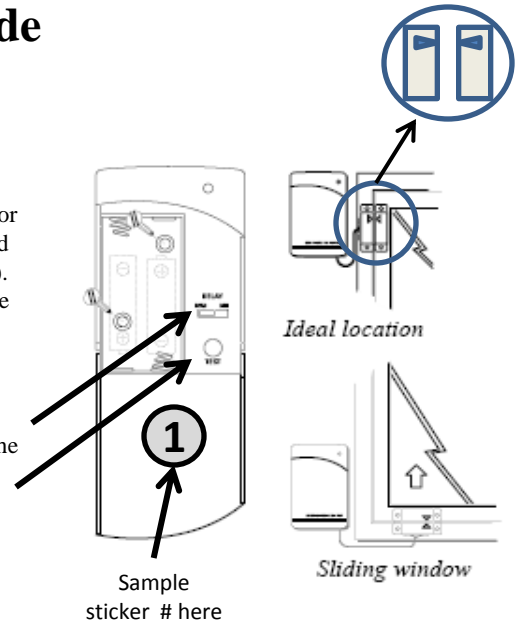

Figure 1



© AllTech Controls



## REO Sentinel™ and Remote Sensor Installation Guide

### Section 2 - Installing the Water Sensor (Figure 2)

1. Place the Water Sensor either flat on the floor using the sticky back tape, or vertically ***making certain*** that the 2 contact prongs are touching the floor. If carpeted, gently push the prongs down into the carpet without bending them.
2. Place the 9V battery (not included) into the blue FD connection device.
3. Mount the blue FD device within reach of the Water Sensor.
4. Mount the white Radio Sensor within cable reach of the blue FD device.
5. ***First*** plug the Water Sensor cable into the jack on the left (as you're looking at the device as shown in Figure 2).
6. Touch the sensor's metal tracks with a damp cloth or your finger to test the alarm. The Blue FD device should beep with the red light blinking.
7. ***Next*** install the two AA batteries into the white Radio Sensor and place a numbered sticker inside the battery compartment door.
8. Press and hold the Test button for 3-5 seconds. Release it and the red light will come on.
9. ***Next*** plug the cable of the white Radio Sensor into the middle jack of the Blue FD device as shown in Figure 2.
10. ***Finally***, touch the Water Sensor a 2<sup>nd</sup> time to make sure the red light on the white Radio Sensor also now comes on.
11. The A/C adapter/wall plug, if included, is optional and not required.



Figure 2



## REO Sentinel™ and Remote Sensor Installation Guide

### Section 3 - Installing the REO Sentinel (Figures 3 & 4)

1. With the ceiling template in hand, press it to the ceiling in the desired location. Be sure the front arrow of the template is facing the desired direction for the Camera and Motion sensor.
2. With a pencil or awl, mark the ceiling in the center of each template hole. These will line up with the holes in the top cover of the REO Sentinel as shown in Figure 3.
3. First screw in the self-tapping anchors where the screw holes were marked.
4. Next tighten the two screws as shown in Figure 4, leaving approximately ¼ inch of space between the ceiling and the screw head.
5. Place the REO Sentinel carefully to the ceiling until the screw heads drop through the mounting holes.
6. Gently twist the Sentinel clockwise about ½” and it will lock securely in place. Slowly remove your hands to ensure the REO Sentinel is secure.
7. Now remove the REO Sentinel from the ceiling and we are ready to activate the Remote Sensors you have installed throughout the property.

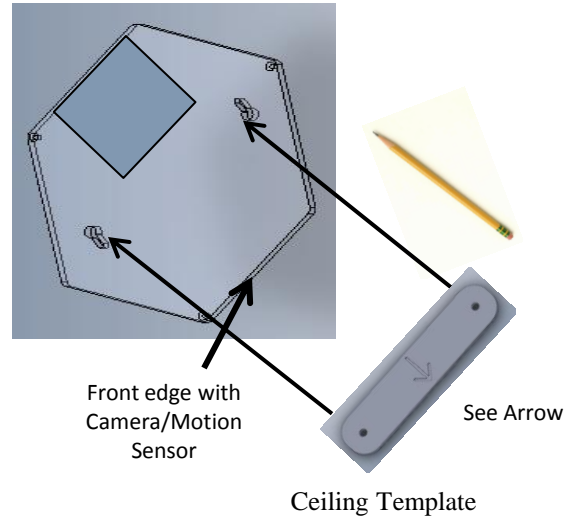

Figure 3

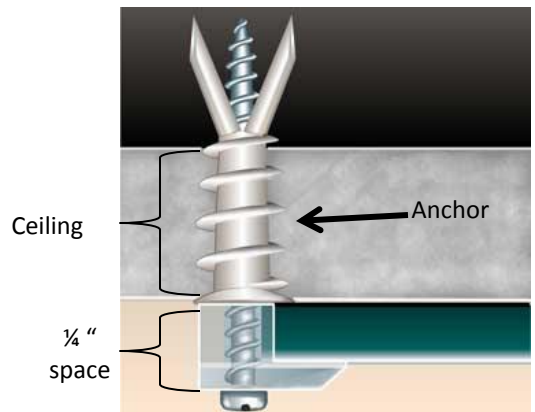

Figure 4



# REO Sentinel and Remote Sensor Installation Guide

**CONGRATULATIONS!!!**

**You are now ready to register remote sensors to the REO Sentinel**

## Section 4 – Record and Register (Figures 5 & 6)

### Step 1: Plot your path

1. Earlier you placed a numbered sticker on each remote sensor. Please record these on the Property Installation card as shown in Figure 5.
2. When you turn on the REO Sentinel later, you will be testing and registering each sensor in exactly the #1 - #2 - #3 - #4... sequence of your stickers.
3. You will have approximately 30 seconds between registering each sensor.

### Step 2: Turning on the REO Sentinel™

1. Open the REO Sentinel battery compartment and install only the batteries provided. (Regular “D” batteries will not work).
2. On the included Property Installation Card (see Figure 5) record the Serial # and SIM # found on the rear of the device or inside the battery compartment.
3. Walk over to where your Sensor #1 is located.
4. Turn on the REO Sentinel™ using the On/Off slide switch within the battery compartment (see Figure 6). The unit will self test and then the green light will blink slowly meaning it is ready to accept registration of the remote sensors.
5. Press and hold the red Registration button. The light will flash very quickly for 5-10 seconds. When the green light on the REO Sentinel stops flashing quickly you are now in registration mode and have approximately 30 seconds to register the first sensor (Step 3 below).

**Note:** *If the green light does not flash quickly for at least 5 seconds, turn the unit off and start again. If the fault still exists please call 1-877-815-7760.*

### Step 3: Registering Sensors

1. To register your first sensor for doors or windows you should open & close them and for water touch the sensor as you did before.
2. You should see a rapid series of flashes in the green LED to indicate the sensor has been detected. The slow blinking pattern of the LED will change to be a long pulse followed by one short pulse. Proceed to sensor #2.
3. After the second sensor is registered, the blinking pattern of the LED will change to be a long pulse followed by two short pulses, and so forth for additional sensors. (Example: 4 sensors = 1 long flash + 4 quick flashes).

**Notes:** *If the Registration Button is held in for 3-5 seconds, all registered sensors will be cleared from memory and you will need to return to Step 2 above. This is especially useful when moving the REO Sentinel and Remote Sensors to new properties.*

5. Once registration of all Remote Sensors is complete, wait 30-40 seconds until the REO Sentinel™ light either turns completely off or stays on solid signifying the process is complete.

The diagram shows a vertical column of 10 numbered circles labeled 'Stickers' on the left. Arrows point from stickers 1, 4, 7, and 10 to the right. On the right is a 'Property Installation Card' with a red border. It contains fields for 'Address: \_\_\_\_\_', 'Serial #: \_\_\_\_\_', and 'SIM #: \_\_\_\_\_'. Below these is a section titled 'Remote Sensor Locations' with 10 numbered lines: '#1 \_\_\_\_\_', '#2 \_\_\_\_\_', '#3 \_\_\_\_\_', '#4 \_\_\_\_\_', '#5 \_\_\_\_\_', '#6 \_\_\_\_\_', '#7 \_\_\_\_\_', '#8 \_\_\_\_\_', '#9 \_\_\_\_\_', and '#10 \_\_\_\_\_'. At the bottom of the card, it says 'Please keep for your records'.

Figure 5

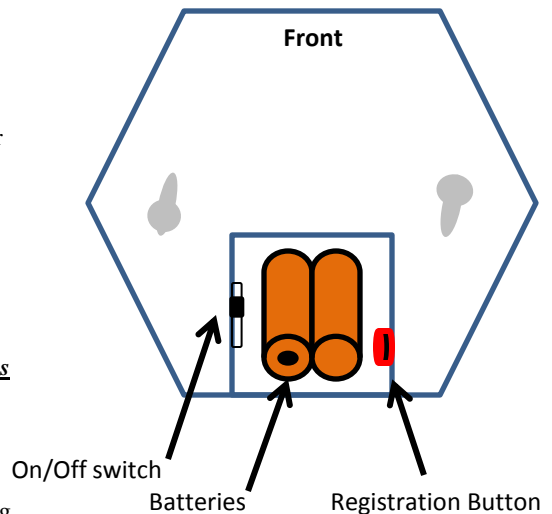

Figure 6



## REO Sentinel™ and Remote Sensor Installation Guide

### Step 4: Final Installation

1. Reposition your ladder in order to place the REO Sentinel™ on the ceiling.
2. Replace the battery compartment door with screw provided.
3. Place it on the mounting screws installed earlier in the ceiling and turn clockwise until it locks in place.
4. The REO Sentinel™ installation is now complete, congratulations!
5. In order to register your installation, please call the Customer Care Center # at the bottom of this page. You will be asked to walk in front of the REO Sentinel™ and stand in place while providing:
  - a) Your Name
  - b) Your Company
  - c) What Company you are installing the device for (if different)
  - d) Your Contact information
  - e) Information from the Property Installation Card
    - a) The Property Address
    - b) The REO Sentinel Serial #
    - c) The REO Sentinel SIM #
    - d) Location of each Remote Sensors *in the exact sequence they were registered.*
6. You may also be asked by the Customer Care Operator to trigger one or two of the sensors you installed.

---

For assistance please contact us at **1-877-815-7760** or through our website  
[www.reosentinel.com](http://www.reosentinel.com).

Thank you for selecting the REO Sentinel.